

DBL1600/3W

Intelligent Charging Computer

Intelligent charger for motor vehicles starter battery
 (Lead acid / Gel / AGM / VRLA)



Abbildung ähnlich / device similar to figure



- 100% qualified for motor vehicles on-board electronic system / airbag
- Use as battery charger, power supply and motor vehicles energy supply in buffer mode (support during diagnosis / flash programming)
- Extensive protection functions and self-protection functions
- Short circuit and reverse polarity protection
- Protection against defective batteries
- Reliable sparking suppression
- Comfortable menu navigation / charging parameter configurable
- Built-in communication interface
- Housing version 'B': Advantageous for industrial production lines
- Status indication via display and high power LEDs
- Menu navigation: English, French, German, Italian, Spanish
- Electrical safety - certifications: EN60335-1, EN60335-2-29, EN61010, EN62233 UL1236,
- Utilized and approved by well known automotive manufacturers
- Wide range of accessories e.g. external visualization of operating state (DBL-SIG-LR remote indicator), mains and charging cable, wall mount adapter etc.

- Option: With mounted heat-sink
- Option: Customized charging parameters
- Option: Operation with low temperature until -40°C
- Option: Battery diagnostic system
- Option: Regeneration charging for deep discharged batteries

DBL1600/3W-derivative table

Type	Input voltage	Output voltage (configurable)		Output current	Cat. No.
		FSV	Charge/trickle (typical)		
DBL1600/3W-14-B-HAN	3AC 380-500V	14,4VDC	14,4/13,8VDC	Nom. / Boost 90A / 105A	107201/0/000
DBL1600/3W-14-B-HAN*	3AC 380-500V	14,4VDC	14,4/13,8VDC	90A / 105A	107140/0/000

*Version with alternative pin assignment of the input connection, see fig. 8.2

Intelligent Charging Computer

DBL1600/3W

Alle Daten gemessen bei 400V 3AC / 50Hz, 70A und 25°C Umgebungstemperatur, wenn nicht anders gekennzeichnet. | All parameters are specified at 400V 3AC / 50Hz, 70A and 25°C ambient, if not marked otherwise.
 Technische Änderungen und Irrtümer vorbehalten. | Technical modifications and mistakes reserved.

Mit den Angaben im Katalog und in den Datenblättern werden Produkte beschrieben, nicht Eigenschaften zugesichert. Belastung mit „Grenzwerten“ (einfache Kombination) ist zulässig ohne bleibende Schäden der Produkte. Betrieb der Geräte mit Grenzwertbelastung für längere Zeit kann die Zuverlässigkeit beeinträchtigen. Grenzwerttoleranzen unterliegen üblichen Schwankungen. | Products are described by information contained in catalogs and data-sheets. It is not be considered as assured qualities. Stresses listed under „Maximum Rating“ (one at a time) may be applied to devices without resulting in permanent damage. The operation of the equipment for extended periods may affect device reliability. Limiting value tolerance are subject to usual fluctuation margins.

1 Input

Input voltage AC	nom. 3x 380-500VAC	Tolerance: 320-552VAC TN-S, TN-C, TT, IT systems
Input frequency	50 - 60Hz	Tolerance: 45 - 65Hz
Input voltage DC	450 - 700VDC	Tolerance: 400-780VDC
Inrush current	No Inrush current	Active regulated limitation / Option: Values modifiable on request (e.g. mains switch-on time delay etc.)
Current consumption at full load	4,5A	-
Power factor	typ. 0,95	-
Hold up time	> 3ms	@ Uout > Uout –10%
Input fuse	-	Use external circuit breaker 3-pole LS, 16 Amps, B-type
Transient over voltage protection	Varistor (4,5kA / 71J)	L1, L2, L3; active transient voltage filter (1000V/1.3ms)
Input connector	3-phase mains connector	<p>Connection of 3AC mains cable at the front side of the device with Harting Connector HAN6E/B in two versions:</p> <p>107201: L1(Pin-1), L2(Pin-2), L3(Pin-4), PE(contacts external)</p> <p>107140: L1(Pin-1), L2(Pin-2), L3(Pin-3), PE(contacts external)</p> <p>PIN assignment – see technical drawing 8.2); Connection of N [neutral] is not permitted!</p> <p>HAN: Mains connection via Harting connector HAN6E/B (Note: Mains connection is NOT hot pluggable! Attention: Included in delivery is only the plug on the device side, The mating plug can be ordered from Deutronic cat. no.: 140442)</p> <p>Further optional connector variants on request:</p> <ul style="list-style-type: none"> a) 4-pole, plug-able screw terminal (4x 0.5-4mm²) b) Mains connection kit with protective cover (cat. no.: 140742) c) Fully pre-assembled mains connection kit (protective cover [see b]), CEKON mains plug as well as customized design / length of mains cable)

2 Output

Output voltage (configurable)	2 - 17VDC	For an output voltage > 15,5VDC the default OVP limit must be changed.
continuous output current	max. 90A	-
Short-term output current (Boost)	max. 105A	-
Boost	Adaptive process	Cooling time depends on boost time (max. 1min). After 1min boost (I _{out} >90A) automatic cooling phase (I _{out} ≤ 90A) of 4min.

Intelligent Charging Computer

DBL1600/3W

Alle Daten gemessen bei 400V 3AC / 50Hz, 70A und 25°C Umgebungstemperatur, wenn nicht anders gekennzeichnet. | All parameters are specified at 400V 3AC / 50Hz, 70A and 25°C ambient, if not marked otherwise.
 Technische Änderungen und Irrtümer vorbehalten. | Technical modifications and mistakes reserved.

Mit den Angaben im Katalog und in den Datenblättern werden Produkte beschrieben, nicht Eigenschaften zugesichert. Belastung mit „Grenzwerten“ (einfache Kombination) ist zulässig ohne bleibende Schäden der Produkte. Betrieb der Geräte mit Grenzwertbelastung für längere Zeit kann die Zuverlässigkeit beeinträchtigen. Grenzwerttoleranzen unterliegen üblichen Schwankungen. | Products are described by information contained in catalogs and data-sheets. It is not be considered as assured qualities. Stresses listed under „Maximum Rating“(one at a time) may be applied to devices without resulting in permanent damage. The operation of the equipment for extended periods may affect device reliability. Limiting value tolerance are subject to usual fluctuation margins.

Current limiting	typ. $\pm 1\%$ of adjusted value	-
Output power	$\leq 1600W$ with boost	Automatic power adjustment depending on input voltage, ambient temperature and load condition
Output connector	Welding cable connector	Plug [-] / socket [+] for wire cross section 16 / 25mm ²
operating modes	charge- / power supply- / AUTO – mode	Further modes on request

3 Regulation accuracy

Tolerance	$\pm 2\%$ over all	-
Load regulation static (10-90%)	$< 0,5\%$	typ. 0,05%
Load regulation dyn. (10-90%)	$< 5\%$	-
Recovery time	$< 1\text{ ms}$	-
Temperature drift	$-25^{\circ}\text{C} \dots +50^{\circ}\text{C}: < 1\%$	(typ. 0,5%; @0-40°C: typ. 0,4%)
Voltage ripple	$< 50\text{ mVpp}$	-
Switching spikes	$< 300\text{ mVpp}$	-

4 EMC (Electromagnetic Compatibility)

RF-emission	EN55011 class B	With signal lamp / interface connection: class A
Harmonic current emissions	EN61000-3-2	-
Immunity	EN61000-6-2	-

5 Enviroment

Operating temperature	$-25^{\circ}\text{C} \dots +60^{\circ}\text{C}$	Automatic output power derating – see cooling; down to -40°C on request
Storage temperature	$- 40^{\circ}\text{C} \dots + 85^{\circ}\text{C}$	-
Cooling	Convection and internal fan	Automatic power reduction at too high temperature due to insufficient convection. In case of fan failure, power reduction to emergency program; processor-controlled fan control and monitoring
Humidity	95%	No operation during dew; coated PCB by varnish
Pollution degree	2	EN61010
Climatic category	3K3	EN60721

Intelligent Charging Computer

DBL1600/3W

Alle Daten gemessen bei 400V 3AC / 50Hz, 70A und 25°C Umgebungstemperatur, wenn nicht anders gekennzeichnet. | All parameters are specified at 400V 3AC / 50Hz, 70A and 25°C ambient, if not marked otherwise.
Technische Änderungen und Irrtümer vorbehalten. | Technical modifications and mistakes reserved.

Mit den Angaben im Katalog und in den Datenblättern werden Produkte beschrieben, nicht Eigenschaften zugesichert. Belastung mit „Grenzwerten“ (einfache Kombination) ist zulässig ohne bleibende Schäden der Produkte. Betrieb der Geräte mit Grenzwertbelastung für längere Zeit kann die Zuverlässigkeit beeinträchtigen. Grenzwerttoleranzen unterliegen üblichen Schwankungen. | Products are described by information contained in catalogs and data-sheets. It is not considered as assured qualities. Stresses listed under „Maximum Rating“ (one at a time) may be applied to devices without resulting in permanent damage. The operation of the equipment for extended periods may affect device reliability. Limiting value tolerance are subject to usual fluctuation margins.

6 General data

Electrical safety		UL1236, EN60335-1, EN60335-2-29, EN61010
Protection class	class I	-
Isolation voltage	3000VAC 500VDC	Input / Output Output / Housing
Efficiency	typ. 91%	-
Housing		Metal, especially designed for car manufacture and service stations. Mounting option at the devices side via 4 screws, size M6 (height of thread 10mm)
Dimensions	390 x 355 x 118mm 390 x 355 x 143mm	standard-version option with heat-sink see figure 8.1
Weight	ca. 7,7 kg ca. 10 kg	standard-version option with heat-sink (both without cables and package)

7 Interfaces

Interface (25-pol. SUB-D) ^{[*1][*2]}		For various purposes (e.g. floating Relays, Remote ON/OFF etc.)
RS232 (9-pol. SUB-D) ^{[*1][*2]}		For communication or firmware update (standard PC interface)
	[*1]	A shielded cable must be used to connect external equipment.
	[*2]	ATTENTION: GND-Pins not galvanically isolated to the power output! When connecting the device with an external control a galvanic isolation must be provided!
Signals		3 high power LED's for operating state indication / alarming
Display		Big sized graphic display
3-key operator panel		Menu navigation as well as configuration / parametrization of operation mode and individual device parameters (among others output voltage, current limits, security parameters, start / stop behavior, short circuit reaction etc.) Extensive functional description see operating instructions

Intelligent Charging Computer

DBL1600/3W

Alle Daten gemessen bei 400V 3AC / 50Hz, 70A und 25°C Umgebungstemperatur, wenn nicht anders gekennzeichnet. | All parameters are specified at 400V 3AC / 50Hz, 70A and 25°C ambient, if not marked otherwise.
Technische Änderungen und Irrtümer vorbehalten. | Technical modifications and mistakes reserved.

Mit den Angaben im Katalog und in den Datenblättern werden Produkte beschrieben, nicht Eigenschaften zugesichert. Belastung mit „Grenzwerten“ (einfache Kombination) ist zulässig ohne bleibende Schäden der Produkte. Betrieb der Geräte mit Grenzwertbelastung für längere Zeit kann die Zuverlässigkeit beeinträchtigen. Grenzwerttoleranzen unterliegen üblichen Schwankungen. | Products are described by information contained in catalogs and data-sheets. It is not be considered as assured qualities. Stresses listed under „Maximum Rating“ (one at a time) may be applied to devices without resulting in permanent damage. The operation of the equipment for extended periods may affect device reliability. Limiting value tolerance are subject to usual fluctuation margins.

8 Dimensions

All dimensions are given in millimeters and have a general tolerance according to DIN ISO 2768 - m.

B-HAN version: Display on the top, interface and connector on the front - mains connection via Harting connector HAN6E/B (Attention - included in delivery is only the plug on the device side, not the mating plug).

The heat sink shown here on the bottom of the device is a selectable option and is not included in delivery.

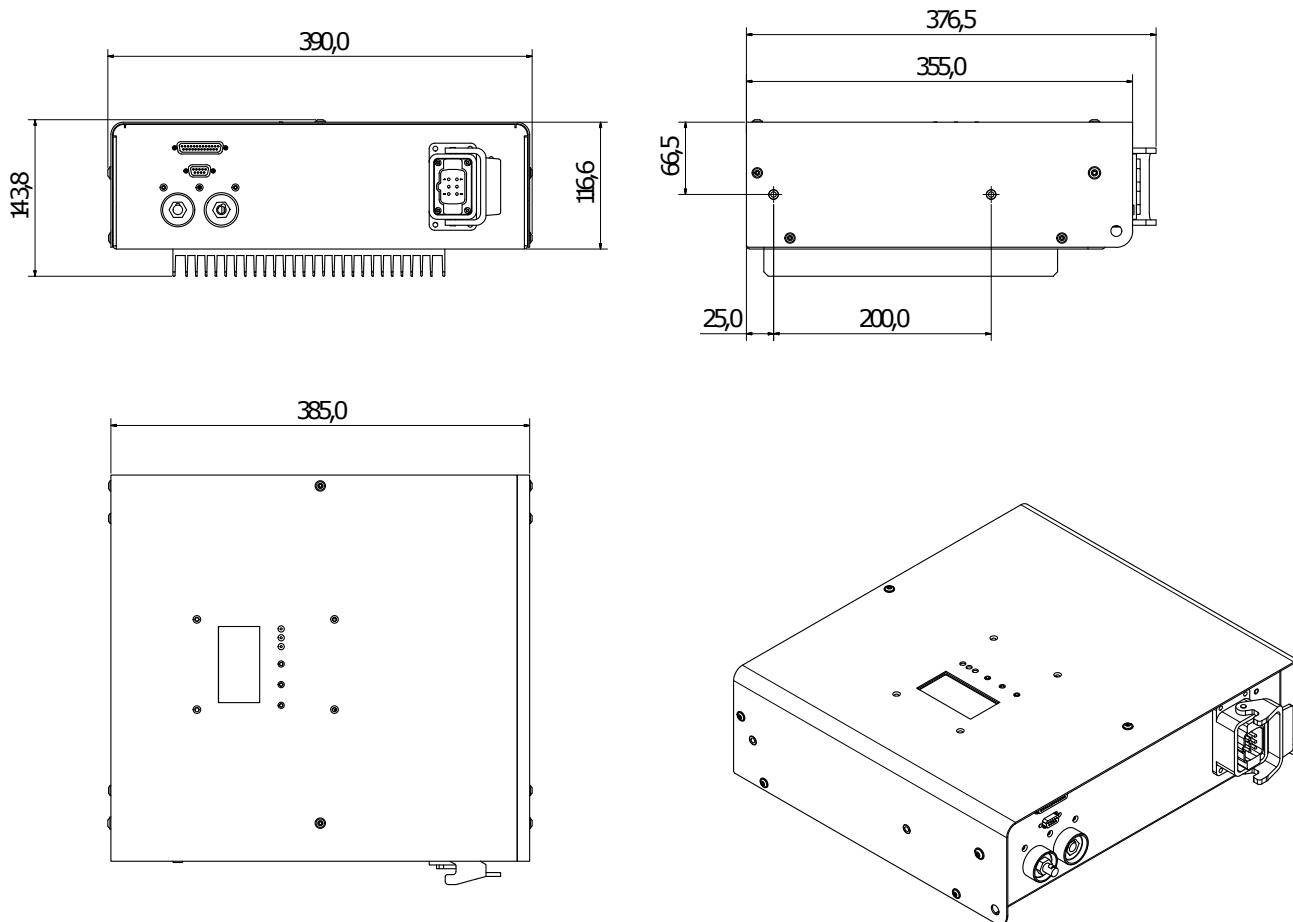

Figure 8.1: dimensions

Figure 8.2: pin assignment of the input connection

Intelligent Charging Computer

DBL1600/3W

Alle Daten gemessen bei 400V 3AC / 50Hz, 70A und 25°C Umgebungstemperatur, wenn nicht anders gekennzeichnet. | All parameters are specified at 400V 3AC / 50Hz, 70A and 25°C ambient, if not marked otherwise.

Technische Änderungen und Irrtümer vorbehalten. | Technical modifications and mistakes reserved.

Mit den Angaben im Katalog und in den Datenblättern werden Produkte beschrieben, nicht Eigenschaften zugesichert. Belastung mit „Grenzwerten“ (einfache Kombination) ist zulässig ohne bleibende Schäden der Produkte. Betrieb der Geräte mit Grenzwertbelastung für längere Zeit kann die Zuverlässigkeit beeinträchtigen. Grenzwerttoleranzen unterliegen üblichen Schwankungen. | Products are described by information contained in catalogs and data-sheets. It is not be considered as assured qualities. Stresses listed under „Maximum Rating“ (one at a time) may be applied to devices without resulting in permanent damage. The operation of the equipment for extended periods may affect device reliability. Limiting value tolerance are subject to usual fluctuation margins.

9 Function description

Attributes	load detection, reverse polarity-, short circuit- and over voltage protection (OVP), cable compensation
Output (Factory settings)	Output voltage monitored by OVP (Over Voltage Protection) and complete disable of output current if preset charging voltage limit is exceeded. Extensive functional description of the charger's features - see operating instructions.
Charge Mode (Factory settings)	When starting the DBL the predefined charging voltage is set (e.g. 14,4VDC). If charging current goes under the predefined limit (e.g. 2,5A) then the charging voltage is reduced to trickle charge (e.g. 13,2VDC). If additional current is required, the charger will again increase the charging voltage (to e.g. 14,4VDC).
Current limiting	Current limit is user selectable. According to the operation state the current limit is automatically adjusted during operation, depending on mains voltage operating temperature, load characteristic etc. The maximum current limit value / boost (see table on page 1) is provided for max. 1 minute continuously followed by a cooling period for approximately 4 minutes.

10 Optional accessories for DBL series chargers

Charging cables (3 and 5 meters), external signal lamp, Ethernet/WLAN adapter, PC software and more accessories you will find on our webpage www.deutronic.com.

(For DBL series chargers with max. output current >100A we recommend using charging cables with a diameter of at least 25mm²).

11 Important (safety-) notes

Generally it is recommended to use by Deutronic released equipment, only. Because only in this way an appropriate technical suitability and an adequate dimensioning can be ensured for professional use.

Equipment and accessories have to be selected and installed in accordance with the requirements and under attention of the existing safety guidelines.

Note: Mains cables / charging cables must be used in completely unrolled condition only, to ensure a sufficient cooling! Moreover pay attention of a safety interlocksystem at the respective device to ensure the operational safety and to avoid damages. If worn, the cables must be replaced immediately!